

NAILFIN / THROUGH  
FRAME INSTALLATION

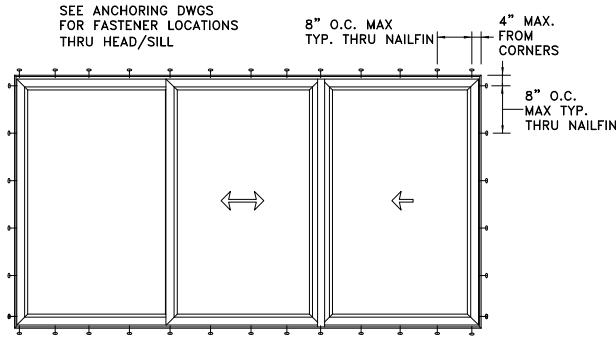

TYPICAL ELEVATION WITH FASTENER SPACING

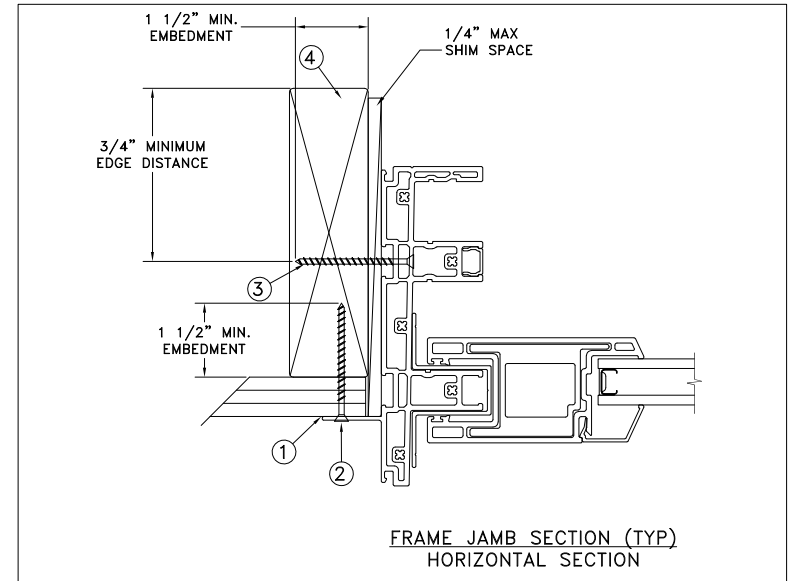
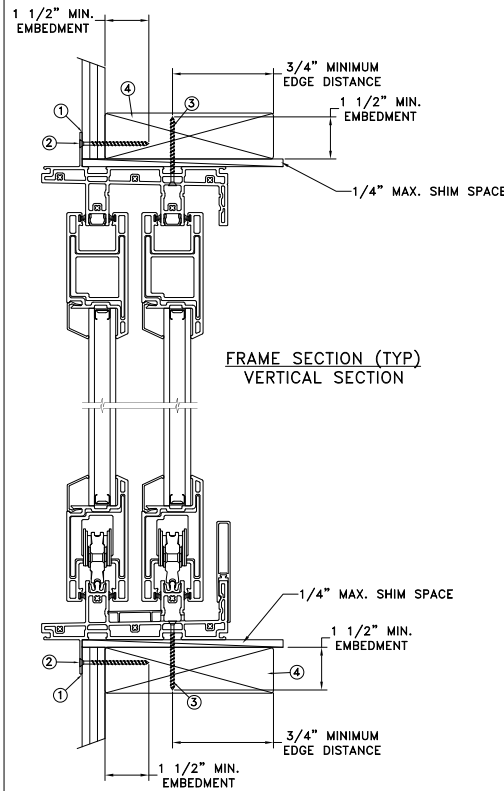

Max Frame	DP	IMPACT
177 x 96	+50/-55	NO

**Installation Notes:**

1. Seal flange/frame to substrate. Sill shall be set on a continuous serpentine bead of structural grade silicone caulk when no fastener is used to anchor the sill (typical).
2. Use #10 PH or greater fastener through the nailfin with sufficient length to penetrate a minimum of 1 1/2" into the wood framing. For 2x wood frame substrate (min. S.G. = 0.42)
3. Use #8 PH or greater fastener through the pre-drilled holes in the head, sill and side tracks at both towers with sufficient length to penetrate a minimum of 1 1/2" into the wood framing. See additional details for location and spacing.
4. Host structure (wood buck, masonry, steel) to be designed and anchored to properly transfer all loads to the structure. The host structure is the responsibility of the architect or engineer of record for the project of installation.

**General Notes:**

1. The product shown herein is designed, tested and manufactured to comply with the wind load criteria of the adopted International Building Code (IBC), the International Residential Code (IRC), the current Florida Building Code (FBC) and the industry requirement for the stated conditions.
2. All glazing shall conform to ASTM E1300.
3. At minimum, glazing is 4.7mm tempered Glass - 12.9mm airspace - 4.7mm tempered Glass
4. Use structural or composite shims where required.

This schedule addresses only the fasteners required to anchor the unit to achieve the rated design pressure and impact performance (where applicable) up to the size limitations noted. It is not intended as a guide to the installation process and does not address the sealing consideration that may arise in different wall conditions. For the complete installation procedure, see the instructions packaged with the unit or go to [www.jeld-wen.com](http://www.jeld-wen.com).

**DISCLAIMER:**

This drawing and its contents are confidential and are not to be reproduced or copied in whole or in part or used or disclosed to others except as authorized by JELD-WEN Inc.

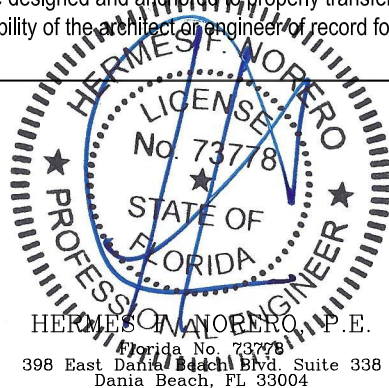

DATE: 11/06/2019	3737 LAKEPORT BLVD. <b>JELD WEN</b> KLAMATH FALLS OR, 97601 PHONE: (800) 535-3936
DRAWN BY: J.HAWKINS	
CHECKED BY: J.GOOSSEN	Premium Vinyl Multi-Slide Patio Door 3-Panel 2-Track OXX Stack
APPROVED BY: J.GOOSSEN	
RECORD No: D015673	
REPORT No: NCTL-210-4025-01	CAD DWG. No.: PremVinylMTSLDR2 Cert
	REV: A SHEET 1 of 8

THROUGH FRAME  
INSTALLATION

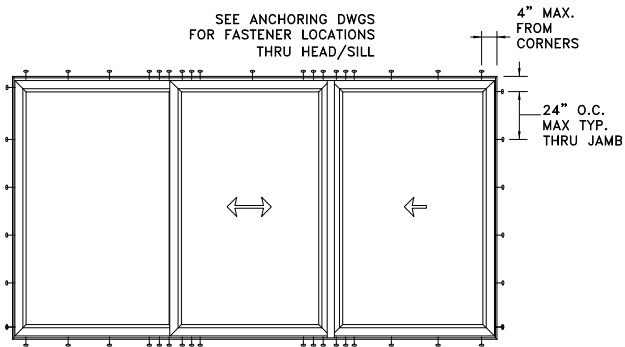

TYPICAL ELEVATION WITH FASTENER SPACING

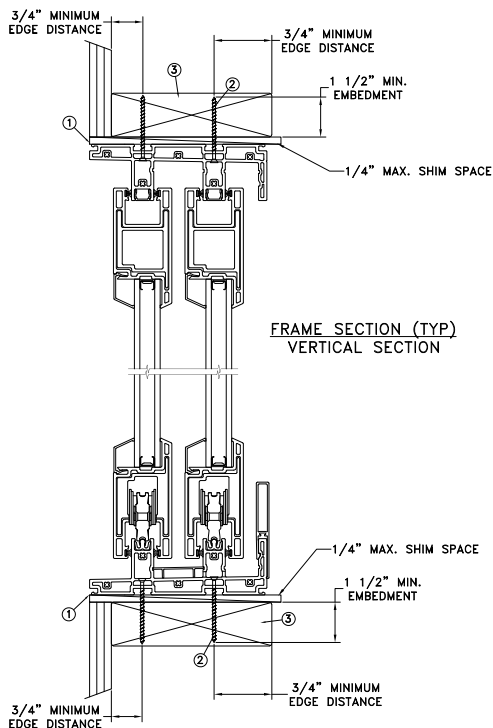

FRAME SECTION (TYP)  
VERTICAL SECTION

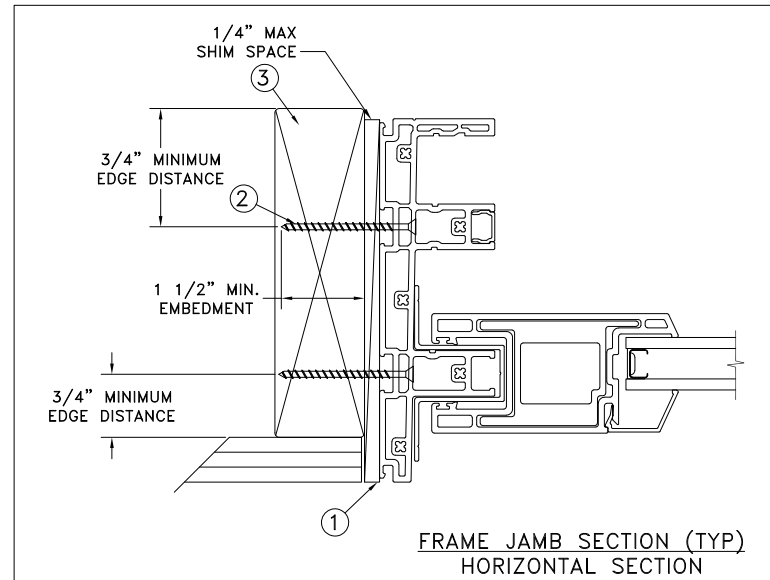

FRAME JAMB SECTION (TYP)  
HORIZONTAL SECTION

Max Frame	DP	IMPACT
177 x 96	+50/-55	NO

**Installation Notes:**

1. Seal flange/frame to substrate. Sill shall be set on a continuous serpentine bead of structural grade silicone caulk when no fastener is used to anchor the sill (typical).
2. Use #14 PH or greater fastener through the pre-drilled holes in the head, sill and side tracks at both towers with sufficient length to penetrate a minimum of 1 1/2" into the wood framing. See additional details for location and spacing. For 2X wood frame substrate (min. SG = 0.42)
3. Host structure (wood buck, masonry, steel) to be designed and anchored to properly transfer all loads to the structure. The host structure is the responsibility of the architect or engineer of record for the project of installation.

**General Notes:**

1. The product shown herein is designed, tested and manufactured to comply with the wind load criteria of the adopted International Building Code (IBC), the International Residential Code (IRC), the current Florida Building Code (FBC) and the industry requirement for the stated conditions.
2. All glazing shall conform to ASTM E1300.
3. At minimum, glazing is 4.7mm tempered Glass - 12.9mm airspace - 4.7mm tempered Glass
4. Use structural or composite shims where required.

This schedule addresses only the fasteners required to anchor the unit to achieve the rated design pressure and impact performance (where applicable) up to the size limitations noted. It is not intended as a guide to the installation process and does not address the sealing consideration that may arise in different wall conditions. For the complete installation procedure, see the instructions packaged with the unit or go to [www.jeld-wen.com](http://www.jeld-wen.com).

**DISCLAIMER:**  
This drawing and its contents are confidential and are not to be reproduced or copied in whole or in part or used or disclosed to others except as authorized by JELD-WEN Inc.

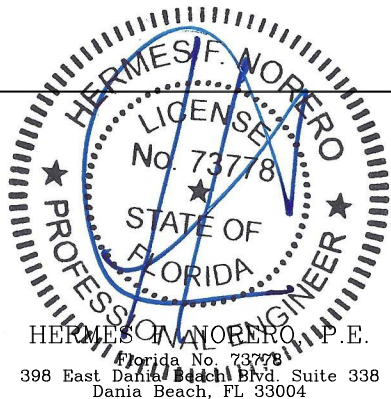

DRAWN BY: <b>J.HAWKINS</b>	DATE: <b>11/06/2019</b>	<b>JELD WEN</b> 3737 LAKEPORT BLVD. KLAMATH FALLS OR, 97601 PHONE: (800) 535-3936
CHECKED BY: <b>J.GOOSSEN</b>	SCALE: <b>NTS</b>	
APPROVED BY: <b>J.GOOSSEN</b>	TITLE: <b>Premium Vinyl Multi-Slide Patio Door 3-Panel 2-Track OXX Stack</b>	
RECORD No: <b>D015673</b>		
REPORT No: <b>NCTL-210-4025-01</b>	CAD DWG. No.: PremVinylMTSLDR2 Cert	REV: <b>A</b> SHEET <b>2 of 8</b>

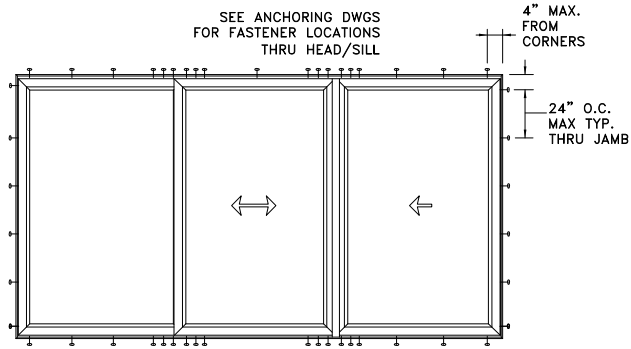

TYPICAL ELEVATION WITH FASTENER SPACING

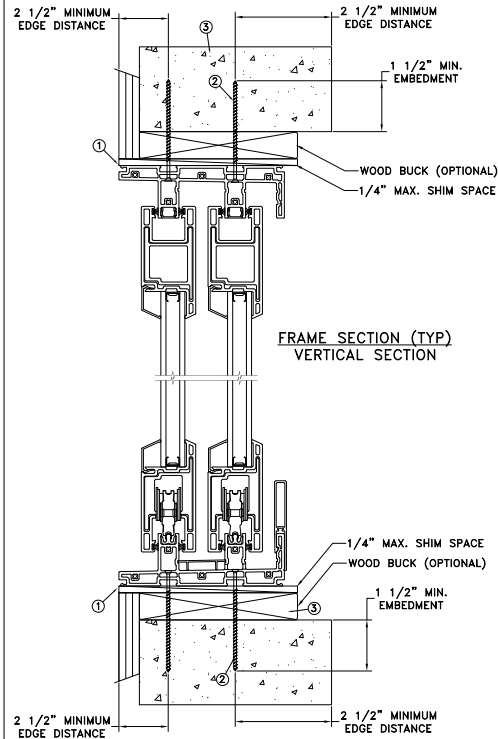

CONCRETE/MASONRY INSTALLATION

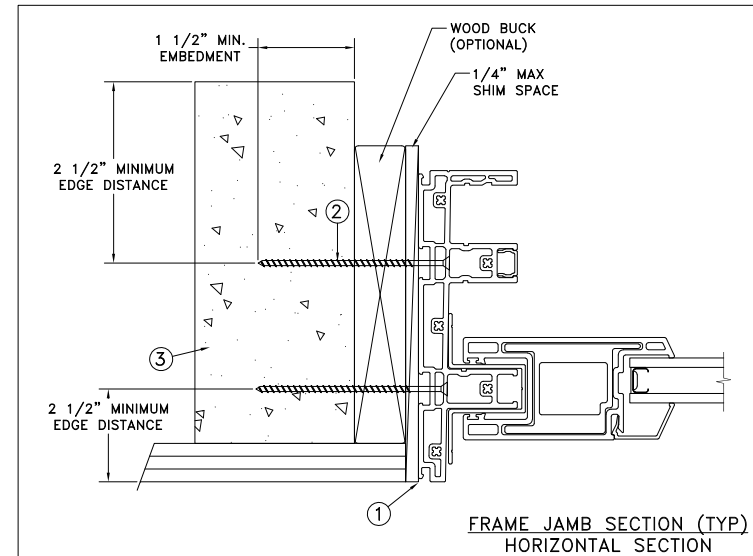

Max Frame	DP	IMPACT
177 x 96	+50/-55	NO

Installation Notes:

1. Seal flange/frame to substrate. Sill shall be set on a continuous serpentine bead of structural grade silicone caulk when no fastener is used to anchor the sill (typical).
2. Use 3/16" tapcon or equivalent fasteners through the pre-drilled holes in the head, sill and side tracks at both towers with sufficient length to penetrate a minimum of 1 1/2" into concrete or masonry at each location with a 2 1/2" min. from edge distance. For concrete (min. fc = 3000 psi) or masonry substrate (CMU shall adhere to ASTM C90).
3. Host structure (wood buck, masonry, steel) to be designed and anchored to properly transfer all loads to the structure. The host structure is the responsibility of the architect or engineer of record for the project of installation.

General Notes:

1. The product shown herein is designed, tested and manufactured to comply with the wind load criteria of the adopted International Building Code (IBC), the International Residential Code (IRC), the current Florida Building Code (FBC) and the industry requirement for the stated conditions.
2. All glazing shall conform to ASTM E1300.
3. At minimum, glazing is 4.7mm tempered Glass - 12.9mm airspace - 4.7mm tempered Glass.
4. Use structural or composite shims where required.

This schedule addresses only the fasteners required to anchor the unit to achieve the rated design pressure and impact performance (where applicable) up to the size limitations noted. It is not intended as a guide to the installation process and does not address the sealing consideration that may arise in different wall conditions. For the complete installation procedure, see the instructions packaged with the unit or go to [www.jeld-wen.com](http://www.jeld-wen.com).

DISCLAIMER:

This drawing and its contents are confidential and are not to be reproduced or copied in whole or in part or used or disclosed to others except as authorized by JELD-WEN Inc.

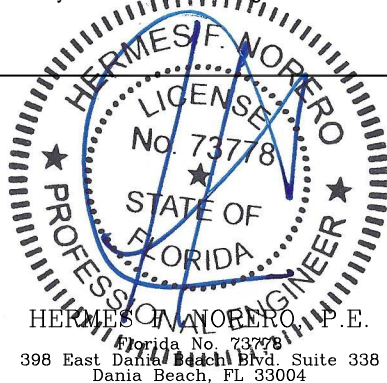

DRAWN BY: J.HAWKINS	DATE: 11/06/2019	<b>JELD-WEN</b> 3737 LAKEPORT BLVD. KLAMATH FALLS OR, 97601 PHONE: (800) 535-3936
CHECKED BY: J.GOOSSEN	SCALE: NTS	
APPROVED BY: J.GOOSSEN	TITLE: Premium Vinyl Multi-Slide Patio Door 3-Panel 2-Track OXX Stack	
RECORD No: D015673		
REPORT No: NCTL-210-4025-01	CAD DWG. No.: PremVinylMTSLDR2 Cert	REV: A SHEET 3 of 8

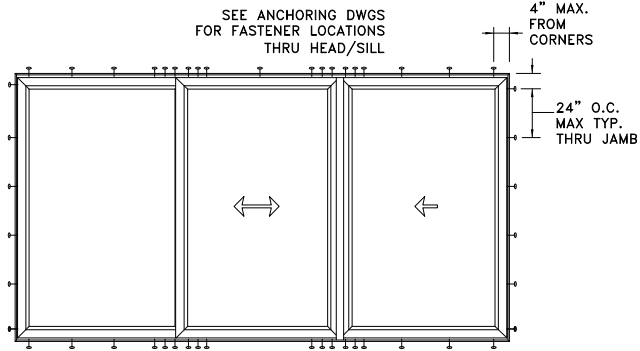

TYPICAL ELEVATION WITH FASTENER SPACING

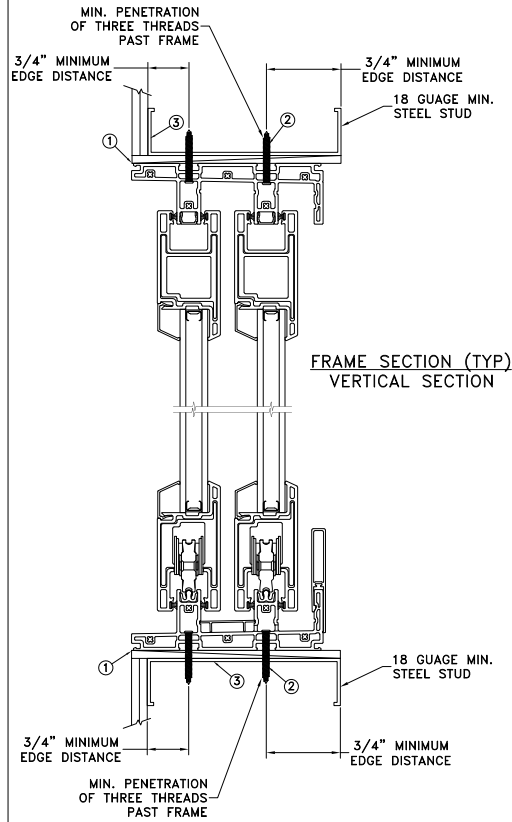

FRAME SECTION (TYP)  
VERTICAL SECTION

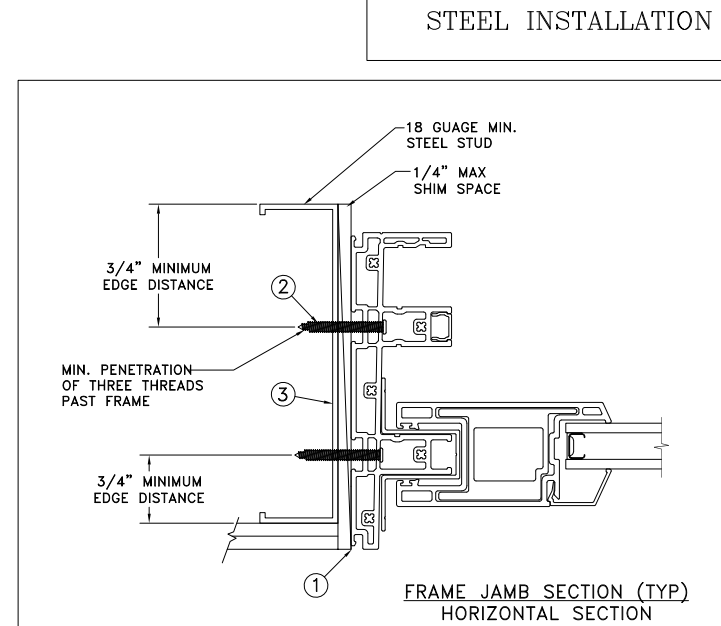

FRAME JAMB SECTION (TYP)  
HORIZONTAL SECTION

STEEL INSTALLATION

Max Frame	DP	IMPACT
177 x 96	+50/-55	NO

**Installation Notes:**

1. Seal flange/frame to substrate. Sill shall be set on a continuous serpentine bead of structural grade silicone caulk when no fastener is used to anchor the sill (typical).
2. For anchoring into metal framing use #12 TEK Self-Tapping screws with sufficient length to achieve a minimum penetration of three threads past the frame thickness. Steel substrate min. 18ga., fy = 33 ksi.
3. Host structure (wood buck, masonry, steel) to be designed and anchored to properly transfer all loads to the structure. The host structure is the responsibility of the architect or engineer of record for the project of installation.

**General Notes:**

1. The product shown herein is designed, tested and manufactured to comply with the wind load criteria of the adopted International Building Code (IBC), the International Residential Code (IRC), the current Florida Building Code (FBC) and the industry requirement for the stated conditions.
2. All glazing shall conform to ASTM E1300.
3. At minimum, glazing is 4.7mm tempered Glass - 12.9mm airspace - 4.7mm tempered Glass.
4. Use structural or composite shims where required.

This schedule addresses only the fasteners required to anchor the unit to achieve the rated design pressure and impact performance (where applicable) up to the size limitations noted. It is not intended as a guide to the installation process and does not address the sealing consideration that may arise in different wall conditions. For the complete installation procedure, see the instructions packaged with the unit or go to [www.jeld-wen.com](http://www.jeld-wen.com).

**DISCLAIMER:**  
This drawing and its contents are confidential and are not to be reproduced or copied in whole or in part or used or disclosed to others except as authorized by JELD-WEN Inc.

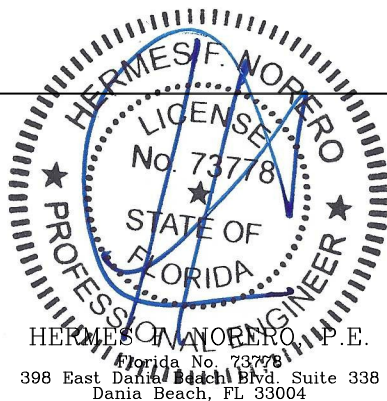

DATE:	11/06/2019	<b>JELD-WEN</b>	3737 LAKEPORT BLVD.
DRAWN BY:	J.HAWKINS		KLAMATH FALLS OR, 97601
CHECKED BY:	J.GOOSSEN	SCALE:	PHONE: (800) 535-3936
APPROVED BY:	J.GOOSSEN	TITLE:	Premium Vinyl Multi-Slide Patio Door
RECORD No:	D015673		3-Panel 2-Track OXX Stack
REPORT No:	NCTL-210-4025-01	CAD DWG. No.:	PremVinylMTSLDR2 Cert
		REV:	A
		SHEET	4 of 8

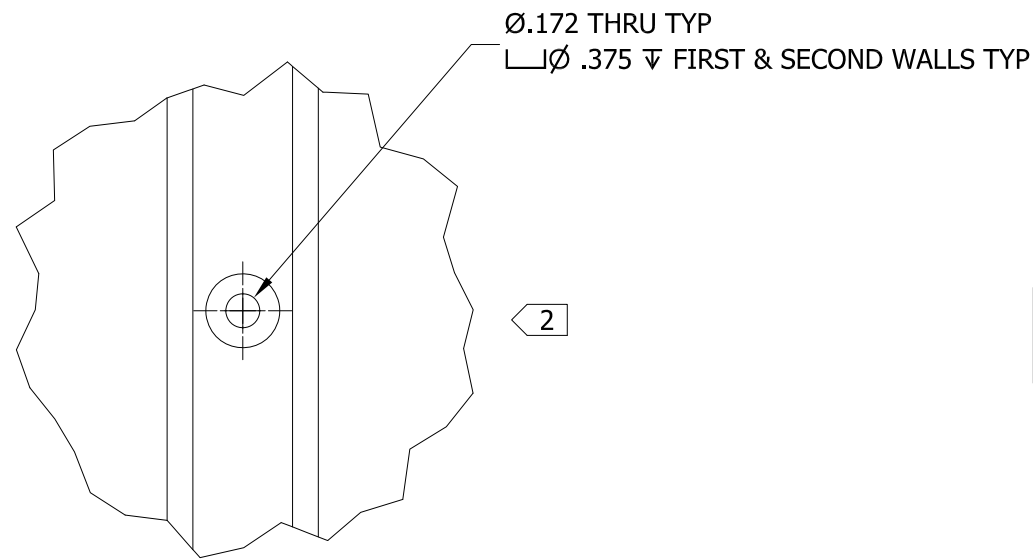
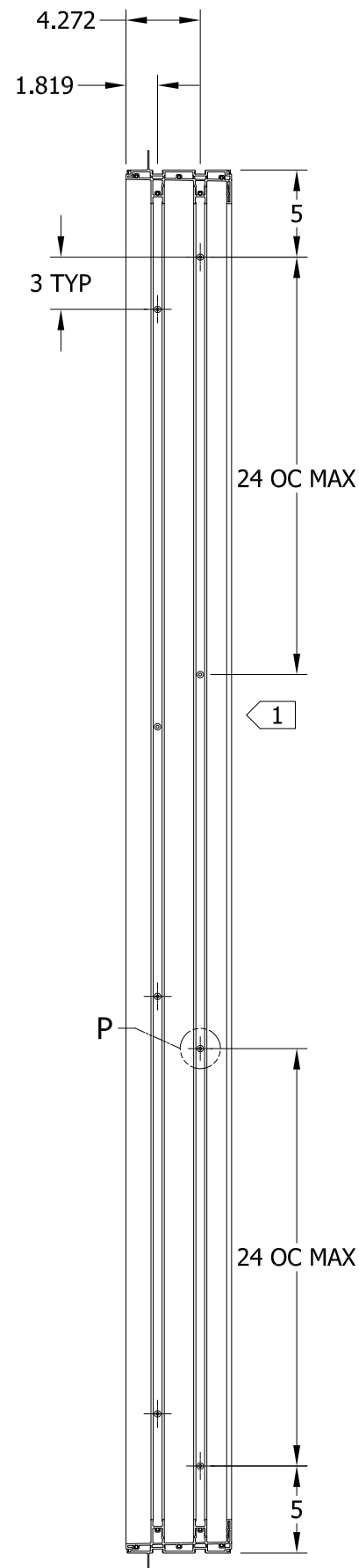

DETAIL P  
SCALE 1 : 1

NOTES:

- 1. ANCHOR PATTERN LOCATED IN TRACK TOWERS 1 & 2 SHIFT AS DETAILED
- 1. HOLES TO BE OMITTED IF ON CENTER CALCULATIONS FALL WITHIN 2" OF KEEPER LOCATION
- 2. ALL HOLES IN ALL POSITIONS TO BE CENTERED WITHIN TRACK TOWERS IN JAMB
- 3. THRU FRAME INSTALLATION

THIS DRAWING NOT INTENDED FOR  
FASTENER SPACING REQUIREMENTS

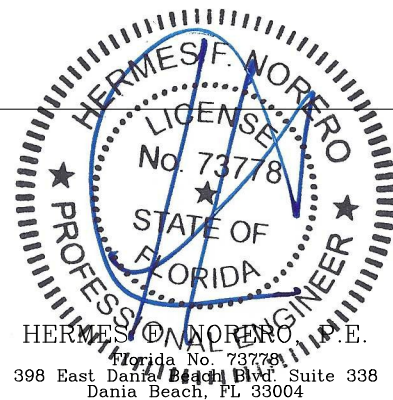

UNLESS SPECIFIED ALL DIMENSIONS IN INCHES  
DO NOT SCALE DRAWING - REPORT ANY ERRORS

TOLERANCES (UNLESS SPECIFIED OTHERWISE)	
COMPONENT / PART TOLERANCES	
UNDER 10'-0" ± 1/32	.X ± .1
OVER 10'-0" ± 1/16	.XX ± .02
ANGULAR ± 1°	.XXX ± .006

UNIT ASSEMBLY TOLERANCES	
HEIGHT ± 1/16	WIDTH ± 1/16
MULLION ± 1/16	FRACTION ± 1/32

PROJECT ENGINEER:  
**N HERTZOG**

DRAWN BY:  
**A BURWELL**

CHECKED BY:  
**J JONES**

APPROVED BY:  
**J JONES**

IDENTIFIER No.

DATE:  
**9/11/2015**

SCALE:  
**1:10**

TITLE:



3737 Lakeport Blvd.  
Klamath Falls, OR 97601  
Phone: (541) 882-3451

**2-TRACK FRAME  
MULTI-SLIDE PATIO DOOR  
JAMB ANCHOR HOLE DETAIL**

MODEL No.:  
**P012967-199.ipt**

DRAWING No.:  
**P012967**

© 2015 JELD-WEN, inc. ALL RIGHTS RESERVED. NO DUPLICATION OR  
DISTRIBUTION PERMITTED. JELD-WEN, inc. CONFIDENTIAL AND PROPRIETARY.

REV: **A** SHEET **5 of 8**

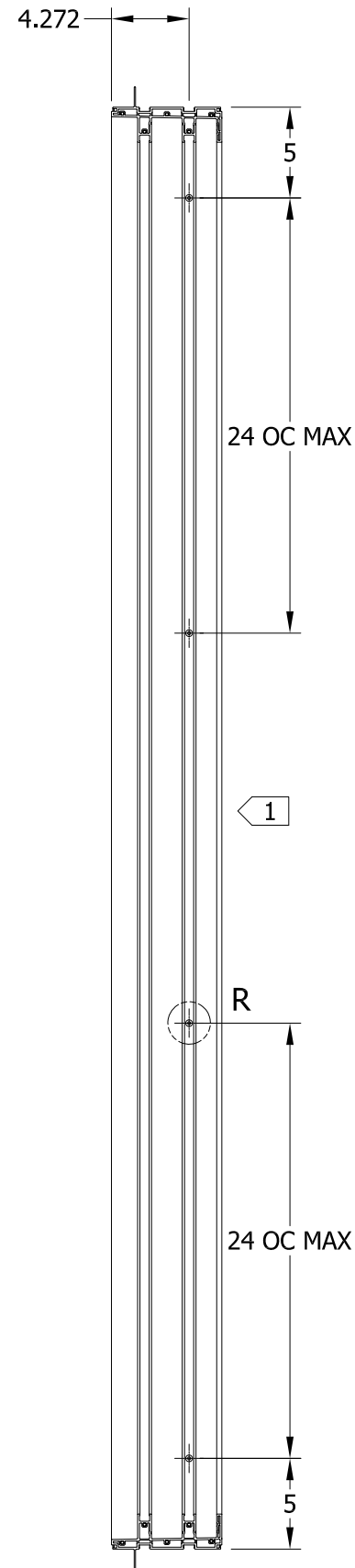

**NOTES:**

- 1. ANCHOR PATTERN LOCATED IN TRACK TOWER 1 SHIFT AS DETAILED
- 1. HOLES TO BE OMITTED IF ON CENTER CALCULATIONS FALL WITHIN 2" OF KEEPER LOCATION
- 2. ALL HOLES IN ALL POSITIONS TO BE CENTERED WITHIN TRACK TOWERS IN JAMB
- 3. NAIL FIN INSTALLATION

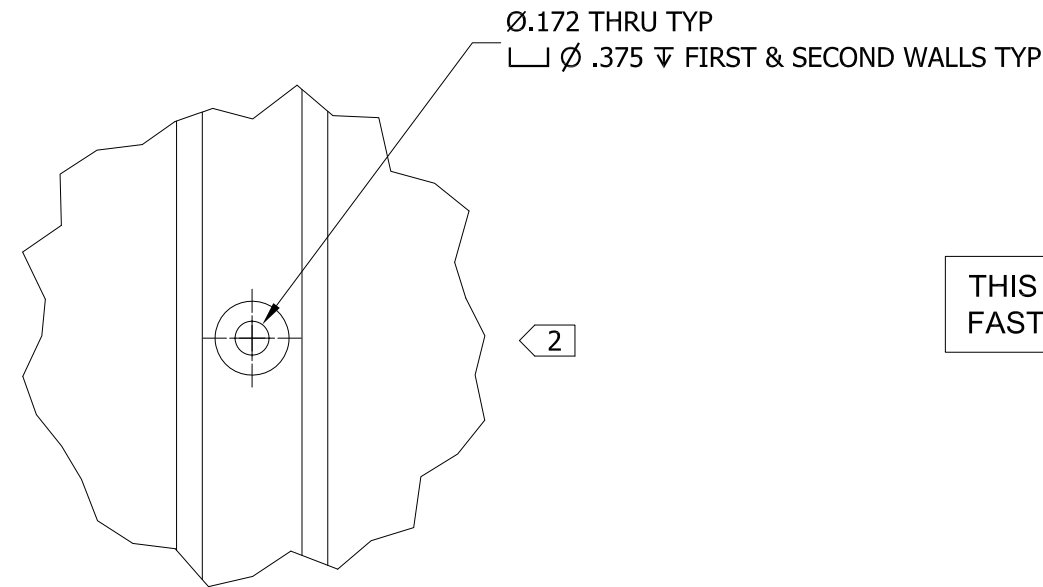

DETAIL R  
SCALE 1 : 1

THIS DRAWING NOT INTENDED FOR  
FASTENER SPACING REQUIREMENTS

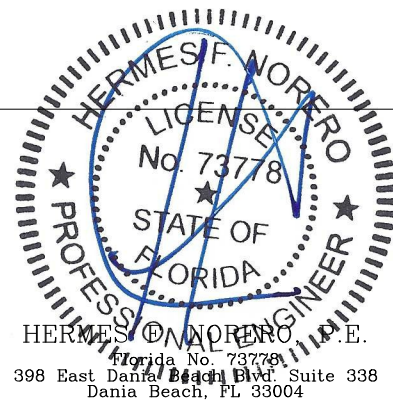

UNLESS SPECIFIED ALL DIMENSIONS IN INCHES  
DO NOT SCALE DRAWING - REPORT ANY ERRORS

TOLERANCES (UNLESS SPECIFIED OTHERWISE)	
COMPONENT / PART TOLERANCES	
UNDER 10'-0" ± 1/32	.X ± .1
OVER 10'-0" ± 1/16	.XX ± .02
ANGULAR ± 1°	.XXX ± .006
UNIT ASSEMBLY TOLERANCES	
HEIGHT ± 1/16	WIDTH ± 1/16
MULLION ± 1/16	FRACTION ± 1/32

PROJECT ENGINEER:  
**N HERTZOG**

DRAWN BY:  
**A BURWELL**

CHECKED BY:  
**J JONES**

APPROVED BY:  
**J JONES**

IDENTIFIER No.

DATE:  
**9/11/2015**

SCALE:  
**1 : 10**

**JELD-WEN**  
WINDOWS & DOORS

3737 Lakeport Blvd.  
Klamath Falls, OR 97601  
Phone: (541) 882-3451

TITLE: <b>2-TRACK FRAME MULTI-SLIDE PATIO DOOR JAMB ANCHOR HOLES DETAIL</b>	MODEL No.: <b>P012967-198.ipt</b>	DRAWING No.: <b>P012967</b>
© 2015 JELD-WEN, inc. ALL RIGHTS RESERVED. NO DUPLICATION OR DISTRIBUTION PERMITTED. JELD-WEN, inc. CONFIDENTIAL AND PROPRIETARY.		REV: <b>A</b> SHEET <b>6 of 8</b>

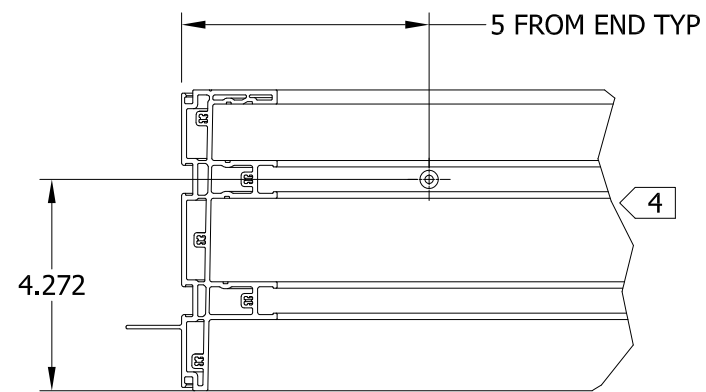

DETAIL S  
SCALE 1 / 4  
EXT ↓

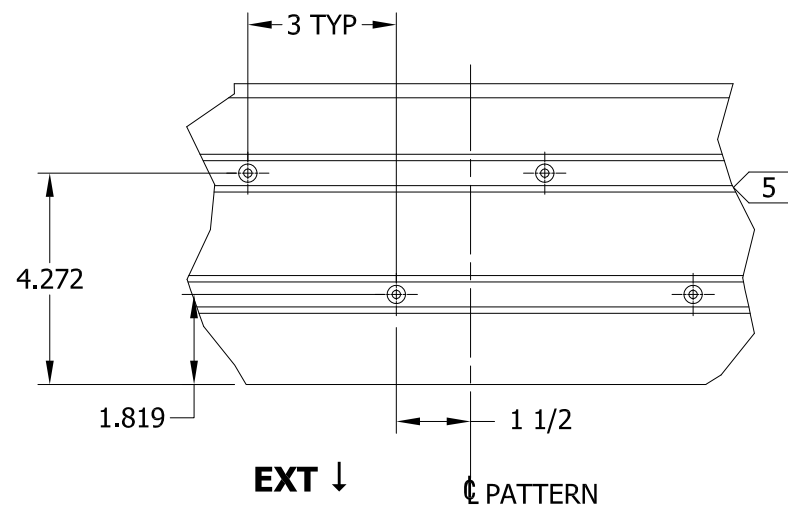

DETAIL T  
SCALE 1 / 4  
EXT ↓

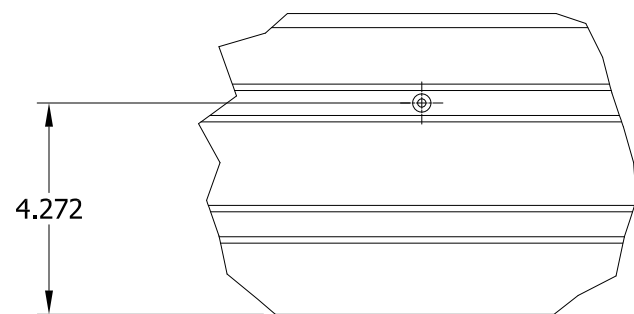

DETAIL U  
SCALE 1 / 4  
EXT ↓

THIS DRAWING NOT INTENDED FOR  
FASTENER SPACING REQUIREMENTS

NOTES:

- 1 ALL HOLES IN ALL POSITIONS TO BE CENTERED WITHIN TRACK TOWERS AT HEAD OR SILL
- 2 TYP 1 ANCHOR PER PANEL LOCATED IN TRACK 1 TOWER AND ALIGNED WITH CENTER POINT OF EACH CLOSED POSITION PANEL
- 3 ANCHOR PATTERN LOCATED IN TRACK 1 & 2 TOWERS AT EACH INTERLOCK AREA
- 4 1 ANCHOR AT ENDS LOCATED IN TRACK 1 TOWER BOTH HEAD AND SILL
- 5 TYP 4 ANCHOR PATTERN LOCATED IN TRACK 1 & 2 TOWERS APPROXIMATE CENTER OF EACH CLOSED POSITION PANEL INTERLOCK AREA
- 6 CONFIGURATION FOR PG50/-55 DOORS WITH THRU FRAME INSTALL

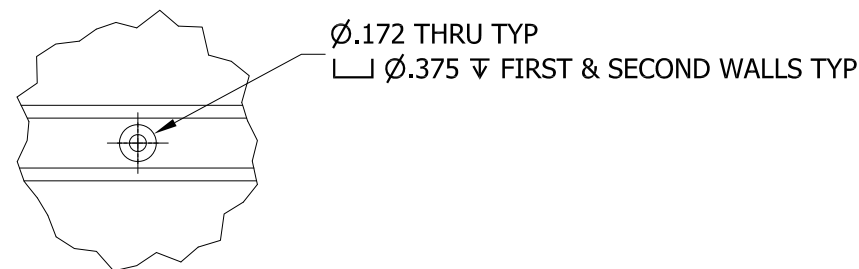
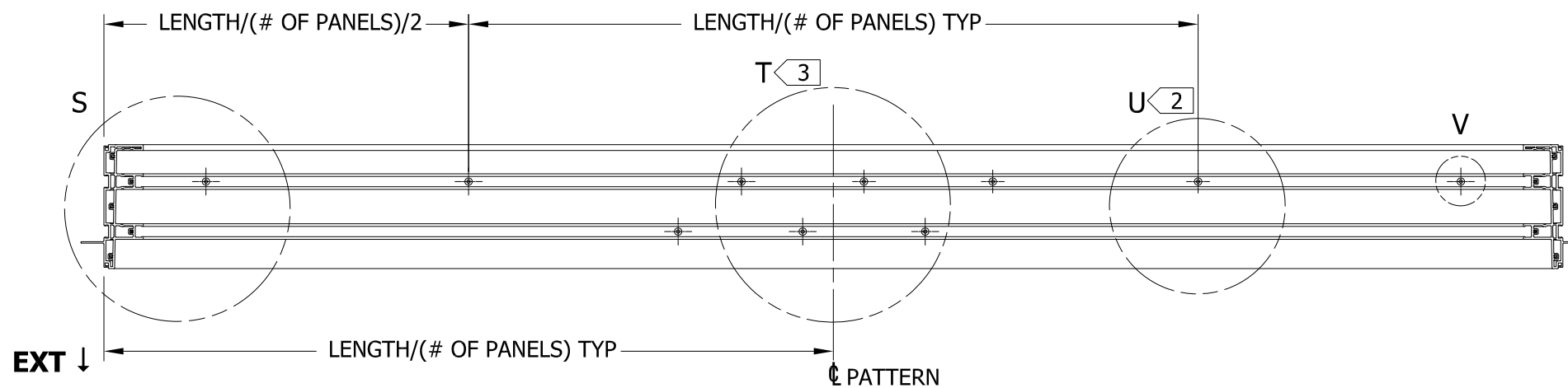

DETAIL V TYPICAL HOLE

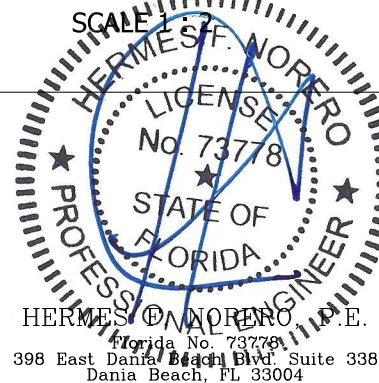

UNLESS SPECIFIED ALL DIMENSIONS IN INCHES  
DO NOT SCALE DRAWING - REPORT ANY ERRORS

TOLERANCES (UNLESS SPECIFIED OTHERWISE)	
COMPONENT / PART TOLERANCES	
UNDER 10'-0" ± 1/32	.X ± .1
OVER 10'-0" ± 1/16	.XX ± .02
ANGULAR ± 1°	.XXX ± .006
UNIT ASSEMBLY TOLERANCES	
HEIGHT ± 1/16	WIDTH ± 1/16
MULLION ± 1/16	FRACTION ± 1/32

PROJECT ENGINEER:  
**N HERTZOG**  
DRAWN BY:  
**A BURWELL**  
CHECKED BY:  
**J JONES**  
APPROVED BY:  
**J JONES**  
IDENTIFIER No.

DATE:  
9/11/2015  
SCALE:  
AS SHOWN



3737 Lakeport Blvd.  
Klamath Falls, OR 97601  
Phone: (541) 882-3451

TITLE:  
**2-TRACK FRAME  
MULTI-SLIDE PATIO DOOR  
SILL AND HEAD ANCHOR HOLES DETAIL**

MODEL No.: **P012967-395.ipt** DRAWING No.: **P012967**

© 2015 JELD-WEN, inc. ALL RIGHTS RESERVED. NO DUPLICATION OR DISTRIBUTION PERMITTED. JELD-WEN, inc. CONFIDENTIAL AND PROPRIETARY.

REV: **A** SHEET **7 of 8**

**NOTES:**

- 1 ALL HOLES IN ALL POSITIONS TO BE CENTERED WITHIN TRACK TOWERS AT HEAD OR SILL
- 2 TYP 1 ANCHOR PER PANEL LOCATED IN TRACK 1 TOWER AND ALIGNED WITH CENTER POINT OF EACH CLOSED POSITION PANEL
- 3 ANCHOR PATTERN LOCATED IN TRACK 1 TOWER AT EACH INTERLOCK AREA
- 4 1 ANCHOR AT ENDS LOCATED IN TRACK 1 TOWER BOTH HEAD AND SILL
- 5 TYP 3 ANCHOR PATTERN LOCATED IN TRACK 1 TOWER APPROXIMATE CENTER OF EACH CLOSED POSITION PANEL INTERLOCK AREA
- 6 CONFIGURATION FOR PG50/-55 DOORS WITH NAIL FIN INSTALL

THIS DRAWING NOT INTENDED FOR FASTENER SPACING REQUIREMENTS

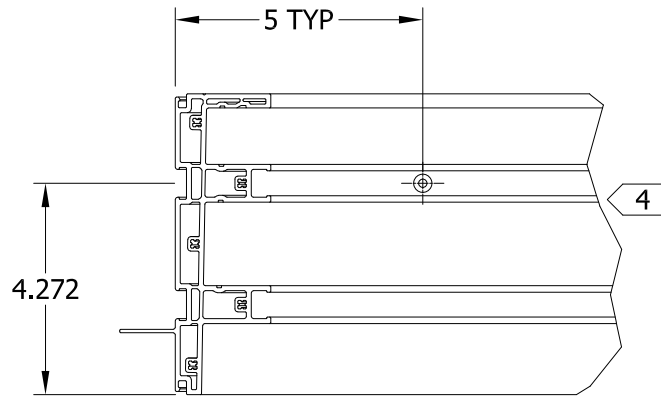

**EXT ↓** DETAIL W  
SCALE 1 / 4

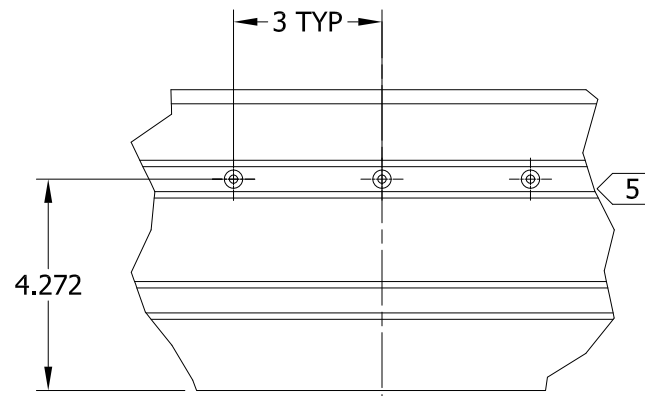

**EXT ↓** PATTERN, SYM  
DETAIL X  
SCALE 1 / 4

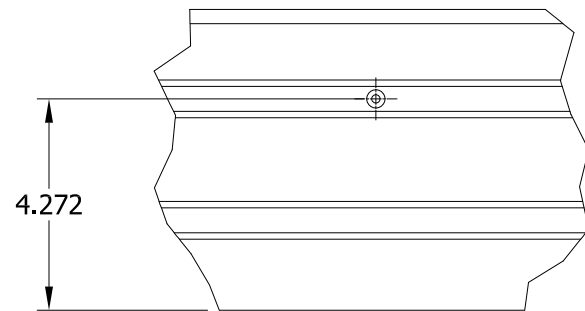

**EXT ↓** DETAIL Y  
SCALE 1 / 4

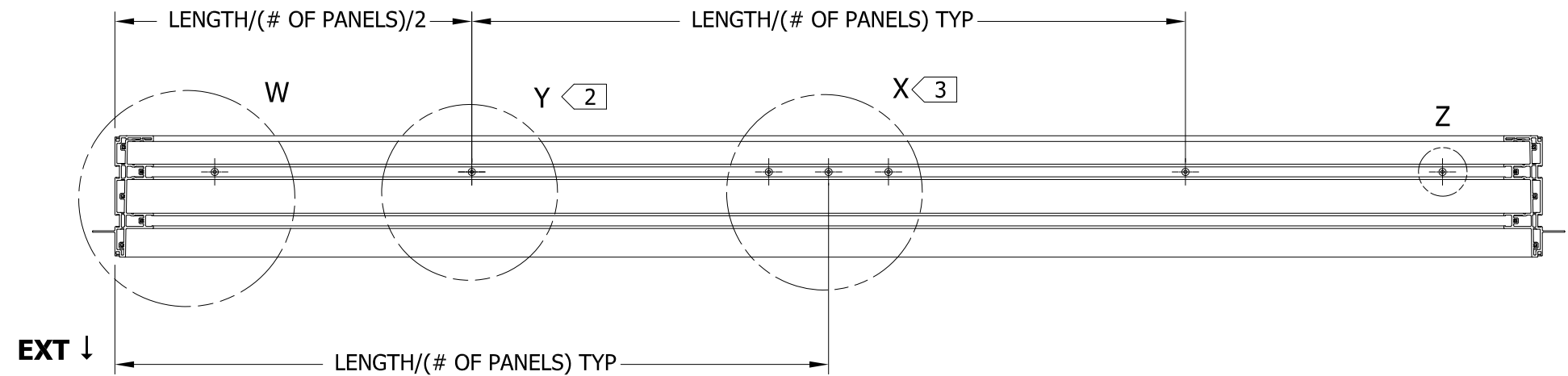

**EXT ↓**

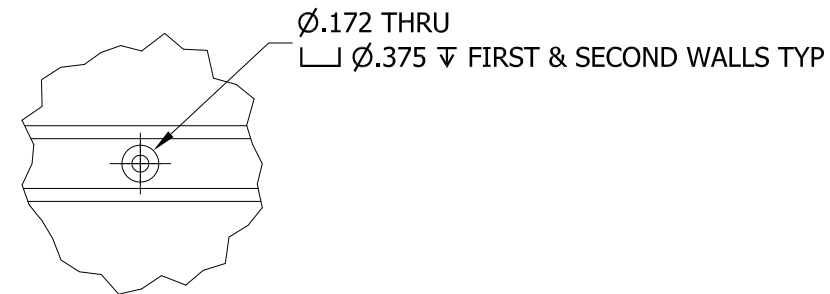

DETAIL Z TYPICAL HOLE  
SCALE 1/2

**HERMES P. NORERO**  
 PROFESSIONAL ENGINEER  
 Florida No. 73778  
 398 East Dania Beach Blvd, Suite 338  
 Dania Beach, FL 33004

UNLESS SPECIFIED ALL DIMENSIONS IN INCHES DO NOT SCALE DRAWING - REPORT ANY ERRORS	
<b>TOLERANCES</b> (UNLESS SPECIFIED OTHERWISE) COMPONENT / PART TOLERANCES	
UNDER 10'-0" ± 1/32	.X ± .1
OVER 10'-0" ± 1/16	.XX ± .02
ANGULAR ± 1°	.XXX ± .006
UNIT ASSEMBLY TOLERANCES	
HEIGHT ± 1/16	WIDTH ± 1/16
MULLION ± 1/16	FRACTION ± 1/32

PROJECT ENGINEER: <b>N HERTZOG</b>
DRAWN BY: <b>A BURWELL</b>
CHECKED BY: <b>J JONES</b>
APPROVED BY: <b>J JONES</b>
IDENTIFIER No.

DATE: 9/11/2015
SCALE: AS SHOWN
TITLE: 2-TRACK FRAME MULTI-SLIDE PATIO DOOR 6 SILL AND HEAD ANCHOR HOLES DETAIL
MODEL No.: P012967-394.ipt
DRAWING No.: P012967

<b>JELD-WEN</b> WINDOWS & DOORS		3737 Lakeport Blvd. Klamath Falls, OR 97601 Phone: (541) 882-3451
© 2015 JELD-WEN, inc. ALL RIGHTS RESERVED. NO DUPLICATION OR DISTRIBUTION PERMITTED. JELD-WEN, inc. CONFIDENTIAL AND PROPRIETARY.		
REV: <b>A</b>	SHEET <b>8 of 8</b>	